



Product designation				Power contactor
Product type designation				BF115
Contact characteristics				
Number of poles	Nr.			3
Rated insulation voltage U_i IEC/EN	V			1000
Rated impulse withstand voltage U_{imp}	kV			8
Operational frequency	min	Hz	25	
	max	Hz	400	
IEC Conventional free air thermal current I_{th}	A			160
Operational current I_e	AC-1 (=40°C)	A	160	
	AC-1 (=55°C)	A	130	
	AC-1 (=70°C)	A	115	
	AC-3 (=440V =55°C)	A	115	
	AC-4 (400V)	A	54	
Rated operational power AC-3 (T=55°C)	230V	kW	37	
	400V	kW	55	
	415V	kW	55	
	440V	kW	55	
	500V	kW	75	
	690V	kW	110	
	1000V	kW	55	
IEC max current I_e in DC1 with L/R = 1ms with 1 poles in series	=24V	A	160	
	48V	A	160	
	75V	A	120	
	110V	A	10	
	220V	A	-	
IEC max current I_e in DC1 with L/R = 1ms with 2 poles in series	=24V	A	160	
	48V	A	160	
	75V	A	160	
	110V	A	130	
	220V	A	14	
IEC max current I_e in DC1 with L/R = 1ms with 3 poles in series	=24V	A	160	
	48V	A	160	
	75V	A	160	
	110V	A	140	
	220V	A	145	
IEC max current I_e in DC1 with L/R = 1ms with 4 poles in series	=24V	A	160	
	48V	A	160	

	75V	A	160
	110V	A	160
	220V	A	160
<hr/>			
IEC max current Ie in DC3-DC5 with L/R = 15ms with 1 poles in series	=24V	A	160
	48V	A	50
	75V	A	40
	110V	A	6
	220V	A	–
<hr/>			
IEC max current Ie in DC3-DC5 with L/R = 15ms with 2 poles in series	=24V	A	160
	48V	A	72
	75V	A	65
	110V	A	65
	220V	A	7
<hr/>			
IEC max current Ie in DC3-DC5 with L/R = 15ms with 3 poles in series	=24V	A	160
	48V	A	150
	75V	A	100
	110V	A	100
	220V	A	92
<hr/>			
IEC max current Ie in DC3-DC5 with L/R = 15ms with 4 poles in series	=24V	A	160
	48V	A	120
	75V	A	120
	110V	A	125
	220V	A	115
<hr/>			
Short-time allowable current for 10s (IEC/EN60947-1)		A	920
<hr/>			
Protection fuse	gG (IEC)	A	200
	aM (IEC)	A	125
<hr/>			
Making capacity (RMS value)		A	1500
<hr/>			
Breaking capacity at voltage	440V	A	1200
	500V	A	850
	690V	A	905
<hr/>			
Resistance per pole (average value)		m?	0.45
<hr/>			
Power dissipation per pole (average value)	Ith	W	11.5
	AC3	W	6.0
<hr/>			
Tightening torque for terminals	min	Nm	6
	max	Nm	7
	min	Ibin	4.4
	max	Ibin	5.2
<hr/>			
Tightening torque for coil terminal	min	Nm	0.8
	max	Nm	1
	min	Ibin	0.59
	max	Ibin	0.74
<hr/>			
Conductor section	AWG/Kcmil		
		max	2/0

Flexible w/o lug conductor section	min	mm ²	1.5
	max	mm ²	70
Flexible c/w lug conductor section	min	mm ²	1.5
	max	mm ²	70
Power terminal protection according to IEC/EN 60529			IP20 front
Mechanical features			
Operating position	normal allowable		Vertical plan ±30°
Fixing			Screw / DIN rail 35mm
Weight		g	2060
Conductor section	AWG/kcmil conductor section		
	max		2/0
Operations			
Mechanical life		cycles	15000000
Electrical life		cycles	1200000
AC coil operating			
Rated AC voltage at 50/60Hz, 60Hz	min	V	100
	max	V	250
Rated AC voltage at 50/60Hz		V	230
AC operating voltage	of 50/60Hz coil powered at 50Hz		
	pick-up		
	min	%Us	80
	max	%Us	110
	drop-out		
	max	%Us	=70 Us min
	of 50/60Hz coil powered at 60Hz		
	pick-up		
	min	%Us	80 Us min
	max	%Us	110 Us max
	drop-out		
	max	%Us	=70 Us min
AC average coil consumption at 20°C	of 50/60Hz coil powered at 50Hz		
	in-rush	VA	70...175
	holding	VA	1.7...3.5
	of 50/60Hz coil powered at 60Hz		
	in-rush	VA	70...175
	holding	VA	1.7...3.5
	of 60Hz coil powered at 60Hz		
	in-rush	VA	70...175
	holding	VA	1.7...3.5
Dissipation at holding =20°C 50Hz		W	1.3...1,5
DC coil operating			
DC rated control voltage	min	V	100
	max	V	250

DC rated control voltage	V	230
DC operating voltage		
pick-up	min	%Us 80 Us min
	max	%Us 110 Us max
drop-out	max	%Us =70 Us min
Average coil consumption =20°C		
	in-rush	W 70...80
	holding	W 1.3...1.5

Max cycles frequency

Mechanical operation	cycles/h	1500
----------------------	----------	------

Operating times

Average time for Us control			
in AC			
Closing NO	min	ms	45
	max	ms	90
Opening NO	min	ms	24
	max	ms	60

UL technical data

Yielded mechanical performance			
for three-phase AC motor			
	200/208V	HP	40
	220/230V	HP	40
	460/480V	HP	75
	575/600V	HP	100

General USE

Contactor			
	AC current	A	165

Short-circuit protection fuse, 600V			
High fault			
	Short circuit current	kA	100
	Fuse rating	A	200
	Fuse class		J
Standard fault			
	Short circuit current	kA	10
	Fuse rating	A	250
	Fuse class		RK5

Ambient conditions

Temperature			
Operating temperature	min	°C	-50
	max	°C	70
Storage temperature	min	°C	-60
	max	°C	+80

Max altitude	m	3000
--------------	---	------

Dimensions

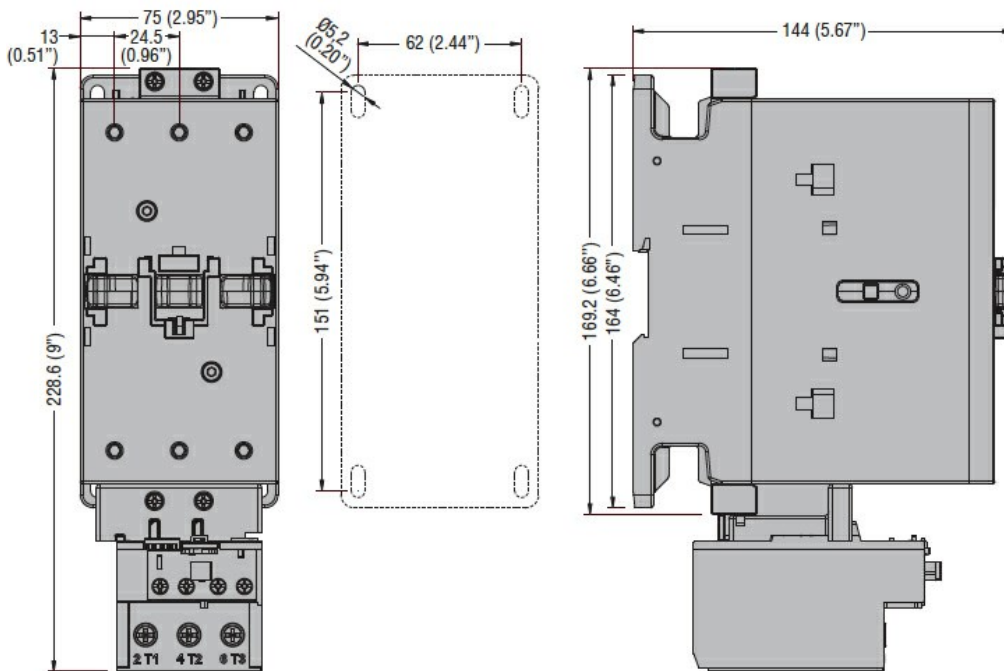

Wiring diagrams

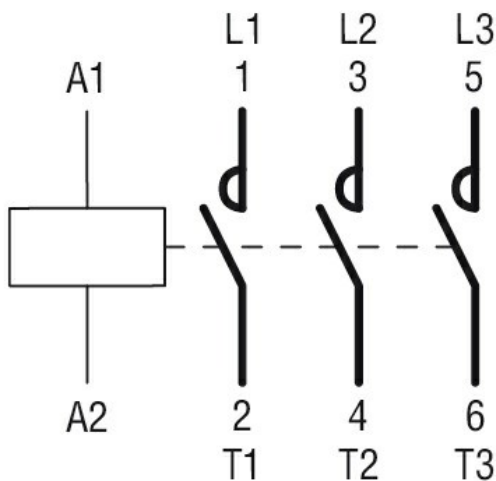

Certifications and compliance

Compliance

CSA C22.2 n° 60947-1
CSA C22.2 n° 60947-4-1
IEC/EN/BS 60947-1
IEC/EN/BS 60947-4-1
UL 60947-1
UL 60947-4-1

Certificates

CCC
cULus

ETIM classification

ETIM 8.0

EC000066 -
Power contactor,
AC switching